

SCREW CONVEYOR SYSTEMS & COMPONENTS



RELIABLE, RESPONSIVE & DECADES OF KNOW-HOW



**THE EXPERIENCE
TO HANDLE IT RIGHT!**

Screw Conveyor Corporation®

Since 1932

SCREW CONVEYOR SYSTEMS & COMPONENTS

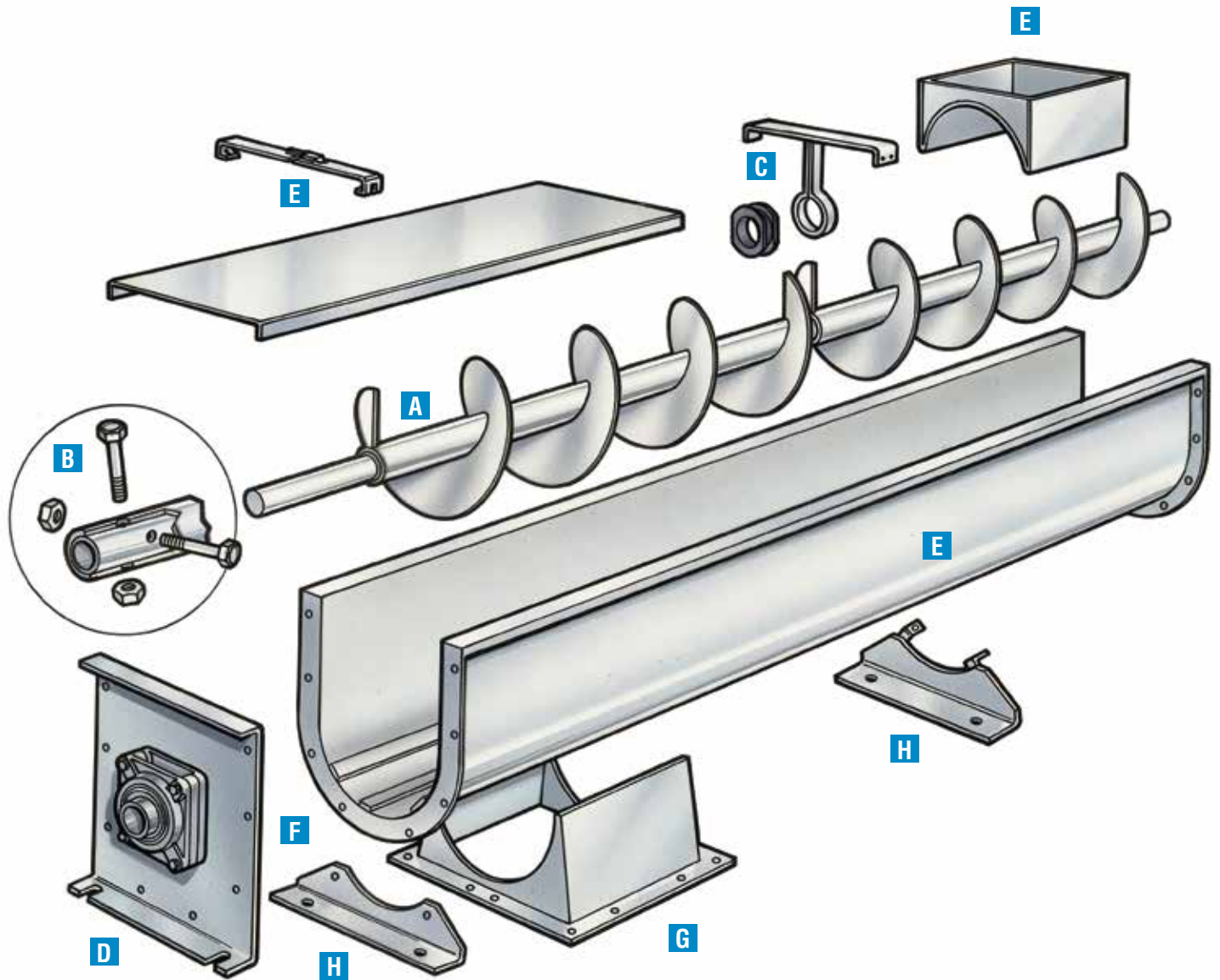

Please refer to Screw Conveyor Corporation Engineering Manual for complete details and part numbers.

NOTE: Applicable CEMA standards are used throughout the product line.

AVAILABLE IN A WIDE RANGE OF DESIGNS & MATERIALS

A WIDE CHOICE OF STANDARD PARTS

You get the system you need to solve your problem — yet keep cost at a minimum. Select the type of component from our standard line that fits your needs. For special flighting designs to solve a particular problem, please consult with one of our four sales offices.

A Conveyor Screw: Compact, manufactured straight and accurate in helicoid, sectional, ribbon and special designs to meet your requirements.

B Job-Rated Components: Selected to meet the performance required. Precisely worked to insure a longer lasting, truer running unit.

Jig-Drilled Couplings: Assures easy shaft alignment and assembly. Available with “Redi-Change” clamping key for quick disassembly of conveyor screw.

Tem-U-Lac Self-Locking Coupling Bolts: Guards against system damage and costly down-time caused by coupling bolts or nuts working loose.

C Hangers and Bearings: Various styles and bearing materials selected to meet your needs.

D Trough Ends: Several bearing and seal styles are available to match your needs.

E Troughs, Covers, Clamps and Shrouds: Ruggedly constructed standard “U” and other styles of troughs including tubular. Covers, clamps and shrouds available for all applications.

F Nu-Weld® Flange: Continuously welded steel flange holds trough in alignment.

G Discharge Spouts: All types available...located where you need them...with hand, electric, hydraulic or pneumatic powered gates.

H Supporting Feet and Saddles: Align and fasten the trough to the floor or existing structure.

A WIDE CHOICE OF MATERIALS

Screw Conveyor parts and assemblies are ideal in a countless number of industries. Their versatility remains a constant even in an era of alternative energy, countless new “bulk” material compounds, and the handling of various hazardous recycled materials. All of these new bulk materials have increased the use of 304 and 316 stainless steel materials, yet the galvanized materials for corrosion protection retain an important business niche. Use of more exotic coatings for shafting (such as tungsten carbide coatings) and ceramic zirconia hanger bearings have found a place in spite of their high cost. Screw conveyors remain a workhorse for the handling of bulk materials.

Wear Resistant Conveyor Components have become a workhorse for the modern industries one serves. Medium grade A/R steel has become common place with many applications demanding A/R 400 or 500 flight and trough materials. Heavy applications of coatings such as postalloy, stellite, etc. to the screw continues to accelerate to meet the demands of 24/7 operations, too.

CARBON STEEL, STAINLESS STEEL, AND GALVANIZED STEEL ARE INVENTORIED AND READY FOR IMMEDIATE DELIVERY!

CONVEYOR SCREWS / FLIGHTS / HANGERS / BEARINGS

HELICOID CONVEYOR SCREWS UP THRU 20"

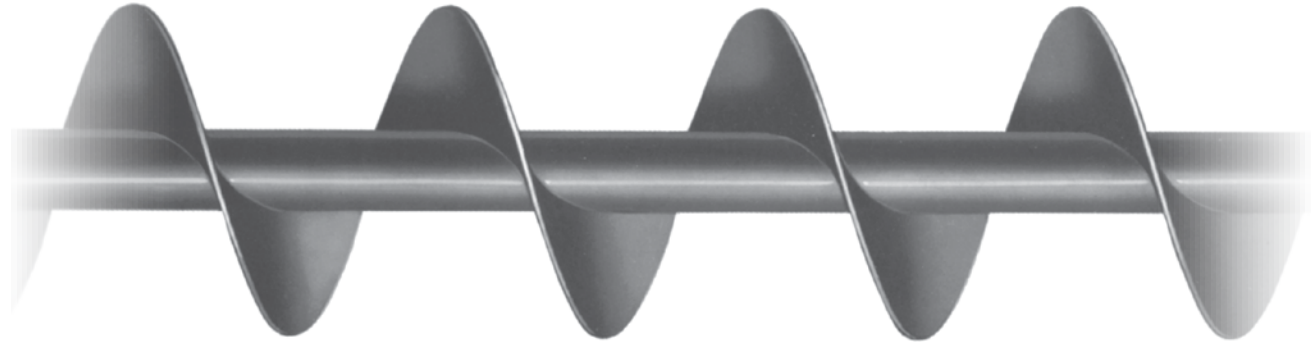

We have all the pieces to put together an answer to your bulk material conveying problem. Screw conveyors handle almost any bulk material efficiently and they do it economically compared to other methods. Compact, they fit into tight places, with moving parts enclosed. They're easy to install and simple to maintain. You can run them horizontally, on an incline, and, with our Screw-Lift®, straight up.

We can meet your application needs in helioid and sectional flight types with adaptations including ribbon, special pitches and tapered – in various gauges of steel, stainless steel and

other alloys, including hardened flight surfaces.

Whether your need is for components or a complete system, you can rely on our years of experience in the engineering and manufacturing of screw conveyors. Consult our experienced personnel without obligation.

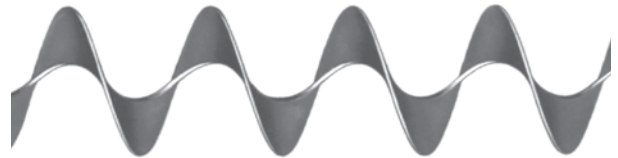

FLIGHTING FOR HELICOID CONVEYOR SCREWS



FLIGHTS FOR SECTIONAL CONVEYOR SCREWS UP THRU 30"



RIBBON CONVEYOR SCREWS

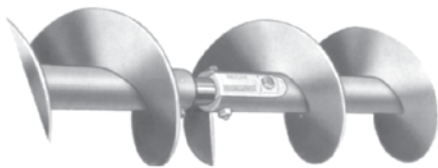

REDI-CHANGE QUICK DISCONNECT CONVEYOR SCREWS

The Redi-Change feature allows you to perform conveyor screw changes and repairs without dismantling the entire conveyor. This feature is available on all types of conveyor screws (not available in 1" shafts).

COUPLINGS

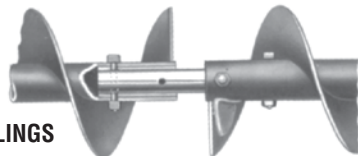

PIPE BUSHINGS



TEM-U-LAC® COUPLING BOLTS

END LUGS



FORMED STEEL LUG FOR DISCHARGE END



FORMED STEEL LUG FOR FEED END

SPECIAL CONVEYOR SCREW DESIGNS

DOUBLE FLIGHT

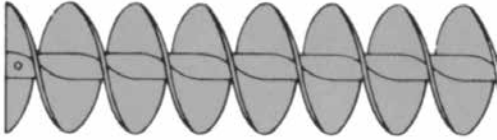

SHORT PITCH

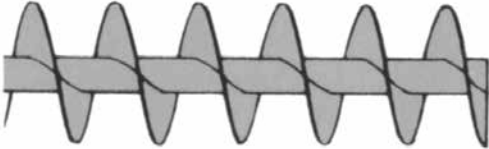

VARIABLE PITCH

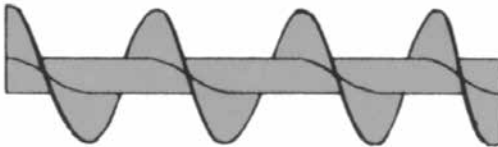

TAPERED DIAMETER

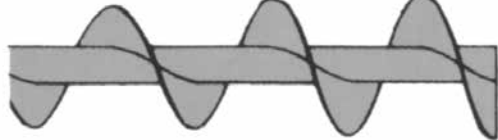

CUT FLIGHTS

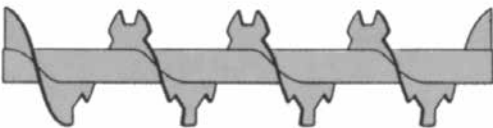

CUT AND FOLDED



MIXING PADDLES (welded or adjustable)

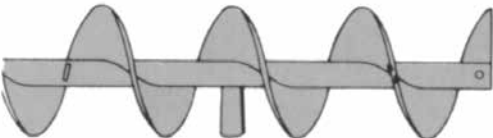

PADDLE CONVEYOR



HANGERS AND REPLACEMENT HANGER BEARINGS

The style 226-Hanger is the most popular since it mounts completely inside the trough and is more suitable for use with dust tight or weather tight covers.

The style 226-Hanger bearings come in Wood, Nylon, Nylatron, Hard Iron, Manganese, Bronze, GATKE, Stellite Bushed, Ceramic Zirconia, and many others.



STYLE NO. 220



STYLE NO. 226



STYLE NO. 260



STYLE NO. 230



STYLE NO. 270



STYLE NO. 216



EXPANSION
STYLE NO. 326



FLARED TROUGH HANGER

BEARING FOR STYLE
220, 226, 326 HANGERS



BEARING FOR STYLE
216, 230 HANGERS



BEARING FOR STYLE
260, 270 HANGERS



TROUGHS & TROUGH ENDS

Troughs are available in sizes up to 30" and in gauges up to 3/8" thick. They can be formed of stainless steel or other alloys. Nu-Weld® end flanges are continuously jig-welded on each end to assure alignment and tight connecting joints. If supporting feet are needed, they are spaced at the flange joints. Trough saddles are also available.



DOUBLE FLANGED TROUGH

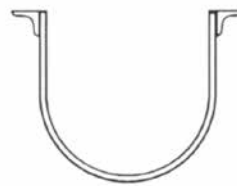

ANGLE TROUGH



SINGLE FLANGED TROUGH

SPECIAL TROUGH DESIGNS



FLARED TROUGH



CHANNEL TROUGH

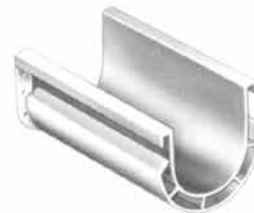

JACKETED TROUGH



TUBULAR TROUGH



DROP BOTTOM TROUGH

Troughs may be furnished in a variety of materials including stainless steel, galvanized, monel or other alloys. Covers are usually bolted on or furnished with screw or spring clamps and may be flat for interior or hip roof for exterior installations. Piano hinges are also available.

TROUGH END DESIGNS



STYLE NO. 100



STYLE NO. 101



DISCHARGE TROUGH END
STYLE NO. 104 AND 107



FLARED TROUGH END
STYLE NO. 114 AND 115



BOLT ON SHELF
(Bolts to existing trough ends)

NU-WELD® END FLANGE

Nu-Weld® end flanges are made of heavy-gauge steel to assure close accurate fit with the conveyor trough and the trough ends of the following end flange. Bolt holes are jig-punched to assure accurate alignment.

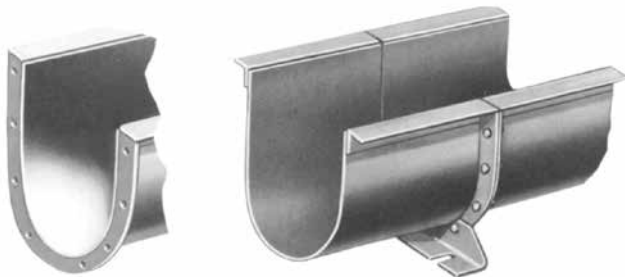

SADDLES AND FEET



TROUGH END DUST SEALS

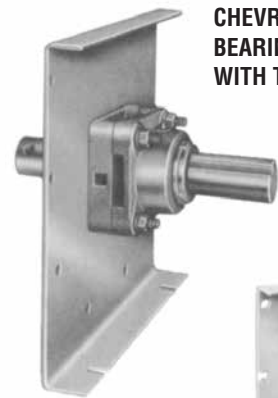

CHEVRON ROLLER
BEARING END THRUST
WITH TROUGH END



ANTI-FRICTION STYLE NO. 102
PICTURED WITHOUT SEAL



ANTI-FRICTION STYLE NO. 103
PICTURED WITH PACKING SEAL

TROUGH COVERS / SHROUDS / COVER CLAMPS



NOTE: Standard designs are not intended to be weather, rain, air, or pressure tight. For special design requirements, contact your nearest sales office.

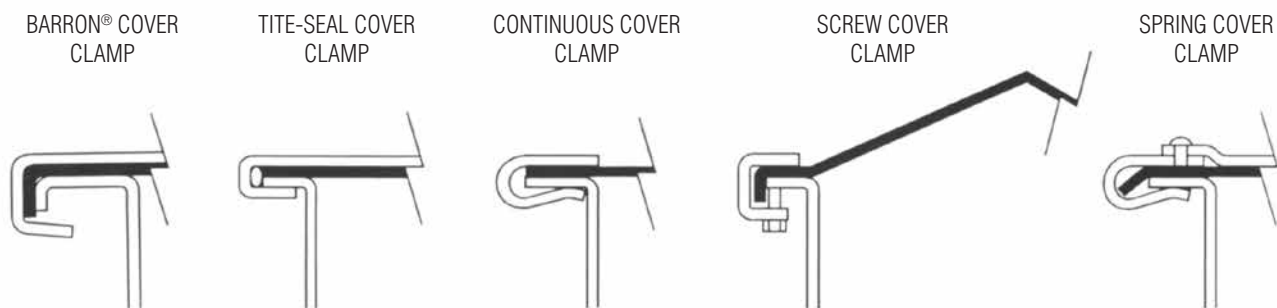

TROUGH COVER CLAMPS



FEED & DISCHARGE SPOUTS

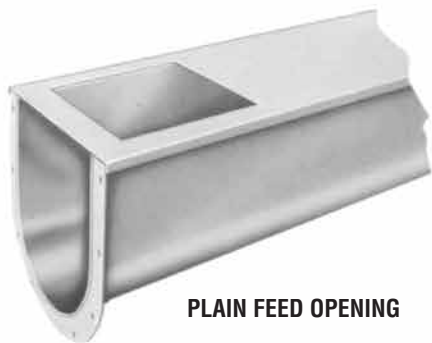

PLAIN FEED OPENING



**DISCHARGE WITH
FLAT-HAND SLIDE**



PLAIN DISCHARGE

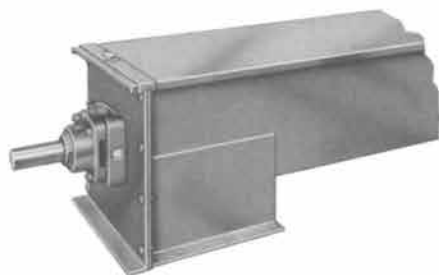

FLUSH END DISCHARGE

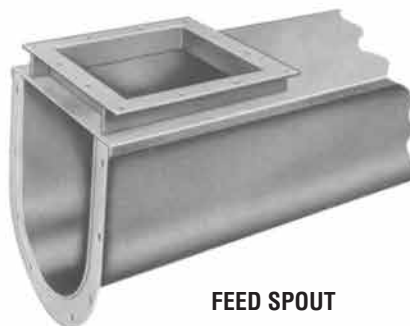

FEED SPOUT



DISCHARGE WITHOUT SLIDE

RACK AND PINION GATES

Rack and pinion gates have cut tooth racks welded to the slide plate. This engages a cut tooth pinion mounted on a pinion shaft. Gate may be operated by hand wheel, chain wheel or power operated by electric motors, air or hydraulic cylinders.



FLAT SLIDE

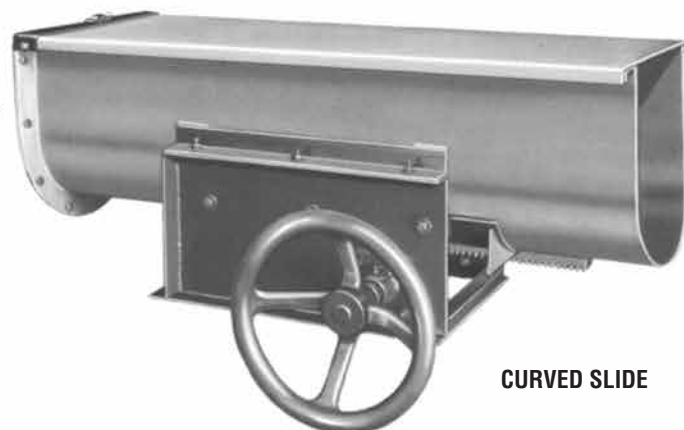

CURVED SLIDE

SCREW CONVEYOR CORPORATION YOUR ONE SOURCE SUPPLIER

SCC Has the Breadth of Experience to Meet Your Bulk Material Handling Needs



Screw Conveyor Corporation has historically covered over 17 SIC codes. Today it is many more with the proliferation of alternative energy applications, recycled materials, and new bulk compounds. As pictured, we have produced a variety of products to meet the needs of today's marketplace. Screw Conveyor Corporation starts from a strong base of quality components stocked at our three US locations, as well as Screw Conveyor de Mexico. By combining base components with the needs of your special application, we have "The Experience to Handle It Right."

We remain committed to serving industry's application needs for the transport of bulk materials. We work every day to strengthen our engineering and application staffing, so our capabilities grow as you grow. We offer it all... smart design, solid construction and reliable performance for over 80 years.

The photos shown on this page represent a cross section of the quality components and replacement parts in stock at three key locations nationwide.



Screw Conveyor Safety Practices



Most accidents involving property damage or personal injury are the result of someone's carelessness or negligence. In order to avoid such accidents, one of the many things that must be done is to make machinery that eliminates in so far as possible an unsafe or hazardous condition. Drag conveyors must be installed, maintained and operated with the following minimum provisions:

1. Screw conveyors shall not be operated unless the conveyor housing completely encloses the moving elements and all power transmission guards are in place. The following warning signs (see CEMA Safety Label Sheet SC-1) are attached to all conveyor housings in locations as specified. Signs should not be removed from housings or be painted over! Replacements can be ordered from the Conveyor Equipment Manufacturer's Association (CEMA).
2. Do not overload the conveyor or use it for anything but its intended use.
3. Feed openings for shovel or other manual or mechanical equipment shall be constructed in such a way that the conveyor rotating and moving parts are enclosed and restricts access to conveyor.
4. Always lock-out power before doing maintenance.

SCC does not perform electrical design services and therefore does not supply electrical devices unless specifically instructed to do so by the purchaser.

SCC will try to assist, to the best of our ability, in the selection of the devices or equipment that will aid the owner and installer in preparing a safe installation and a safe working place. Zero speed switches and other electrical devices can sense conveyor operation so that operations can be interrupted and/or alarms can be actuated.

There are many kinds of electrical interlocking devices for conveyors, elevators and conveyor systems such that if one conveyor in a system or process is stopped, other equipment feeding it or following it can also be automatically stopped and thus prevent overloading at transfer points. For the safety of those that will come into the area where this equipment will be operating we recommend that you contact an electrical designer and/or supplier. Provide them with information on your operating conditions so they can best recommend and supply the appropriate devices.

A copy of Screw Conveyor Safety and Service Instructions are shipped as part of every order.



Screw Conveyor Corporation®

Since 1932

**Performance proven industrial
bulk material handling
equipment for almost a century.**

Technology, reliability and craftsmanship are the keys to almost 100 years of continued growth. Today, we're one of the nation's oldest manufacturers of bulk material handling equipment-including screw conveyors, drag conveyors, vertical lifts and bucket elevators. At Screw Conveyor Corporation we stand behind everything we specify, manufacture and sell...From complete customized bulk material handling equipment to replacement parts.

*We offer these guarantees because we have...
"The Experience to Handle it Right!"*



Proud Member of



**THE EXPERIENCE
TO HANDLE IT RIGHT!**

Screw Conveyor Corporation®

Since 1932

700 Hoffman Street, Hammond, IN 46327-1894

Phone 219-931-1450

www.screwconveyor.com

Winona, MS
P: 662-283-3142

Visalia, CA
P: 559-651-2131

Guadalajara, México
P: 333-645-7110