

Screw-Lift[®] Conveyor for Efficient Elevation



Screw-Lift[®]

**When Your
Handling Problem
Calls for
Elevating
Bulk Materials**



**THE EXPERIENCE
TO HANDLE IT RIGHT!**[®]

Screw Conveyor Corporation

Screw-Lift®...elevate, convey,



Two Screw-Lifts at work in a minimum of floor space.

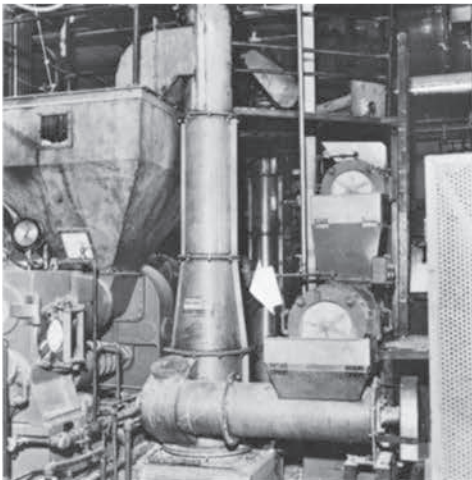

Starch is elevated in this stainless steel Screw-Lift.



Multiple installation shows compact arrangement possible with the Screw-Lift.

Application Versatility and Engineering Capabilities

The Screw-Lift Conveyor is ideal for elevating, distributing and reclaiming an exceptionally wide range of bulk materials efficiently in a minimum of valuable floor space. Generally speaking, if your material is not extremely abrasive and can be conveyed in a horizontal Screw Conveyor application, it can be elevated in a Screw-Lift Conveyor... and without

many of the problems inherent in other types of elevating equipment. The Screw-Lift Conveyor can be used in several configurations for a variety of materials, and Screw Conveyor Corporation has a staff of experienced application and product engineers to assist you in any special design or application requirements.

Partial list of products handled by the Screw-Lift

- Alfalfa meal
- Brewers spent grain
- Carbon black
- Casein
- Cement
- Cereals
- Charcoal
- Chemicals
- Coffee, powdered
- Cork
- Cottonseed
- Feeds
- Flours
- Grains
- Herbs
- Ice, cubes and crushed
- Lime
- Malt
- Meat scraps
- Meals, bone, fish, soybeans, etc.
- Milk powdered
- PVC
- Paper pulp
- Peanuts
- Pepper
- Plaster of Paris
- Plastics
- Rubber, pulverized
- Salt
- Sawdust
- Soap chips
- Soda Ash
- Starch
- Sugar
- Tankage
- Tobacco powder
- and many other materials



Screw-Lift and feeder moves material from floor to distributing conveyor over bins.

distribute, recycle, reclaim

Efficient Design

The Screw-Lift is not merely a tubular screw conveyor operated in a vertical plane. The expanded feeder junction's special conveyor screw flight arrangement with high speed rotation provides the elevating action rather than extruding the conveyed material through a solidly filled tube.

Important Advantages

- Flexibility in design and arrangement. Available in 5 basic models and 3 sizes.
- Highly efficient transfer of materials from horizontal to vertical.
- Savings of valuable floor space with less overall height requirement.
- Material discharge in any direction.

Conveying Principle

The conveyor screw operating in a vertical portion of the Screw-Lift is constructed so that it gets the material started upward most efficiently. The horizontal conveyor

screw in those units incorporating a feeder is designed and synchronized from a speed and rotation standpoint to provide a uniform and smooth transfer of material from horizontal to vertical.

Ease of Installation

The Screw-Lift is compact and requires little floor space. Each unit is assembled and test operated at the factory. It is then match-marked, disassembled and crated for shipment. Assembly in the field requires only following the match-marks and installation and operating instructions supplied with each Screw-Lift.

Materials of Construction

Screw-Lift Conveyors are made of carbon steel as standard. They can also be constructed of series 300 and 400 stainless steel for special applications. They can be hot dipped galvanized for certain corrosive conditions. Abrasion resistant steel flights can be provided.



Candy manufacturer employs Screw-Lift in ingredient distribution system.



Installation illustrates Screw-Lift's compact arrangement with other equipment.

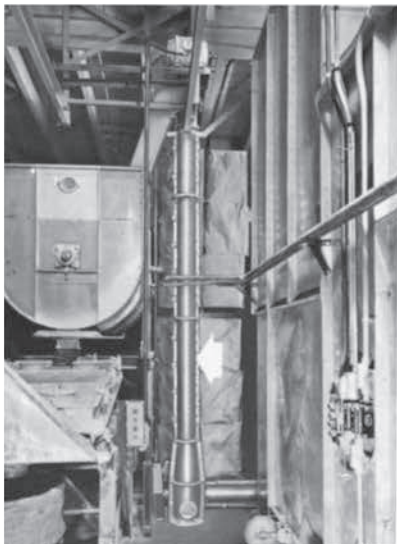

This stainless steel, quick opening type Screw-Lift handles ice cream mix.



Outdoor installation shows two Screw-Lifts at large feed processing plant.

Screw-Lift[®] ...efficient elevation

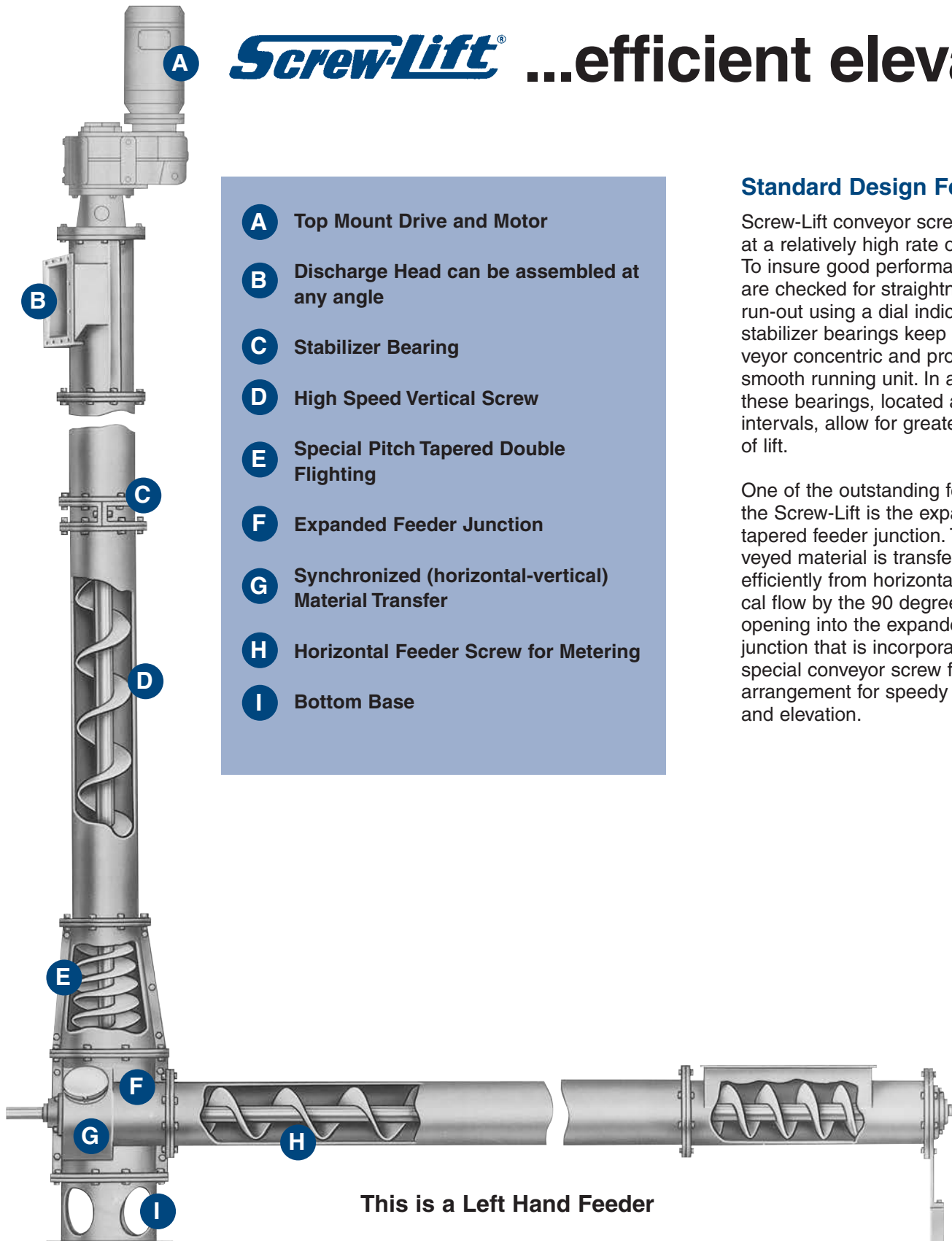

- A** Top Mount Drive and Motor
- B** Discharge Head can be assembled at any angle
- C** Stabilizer Bearing
- D** High Speed Vertical Screw
- E** Special Pitch Tapered Double Flighting
- F** Expanded Feeder Junction
- G** Synchronized (horizontal-vertical) Material Transfer
- H** Horizontal Feeder Screw for Metering
- I** Bottom Base

Standard Design Features

Screw-Lift conveyor screws rotate at a relatively high rate of speed. To insure good performance they are checked for straightness and run-out using a dial indicator. The stabilizer bearings keep the conveyor concentric and provide for a smooth running unit. In addition, these bearings, located at proper intervals, allow for greater heights of lift.

One of the outstanding features of the Screw-Lift is the expanded tapered feeder junction. The conveyed material is transferred most efficiently from horizontal to vertical flow by the 90 degree side opening into the expanded feeder junction that is incorporated with a special conveyor screw flight arrangement for speedy pick up and elevation.

This is a Left Hand Feeder

of bulk materials

The Screw-Lift is constructed with a tubular housing. The housing is fabricated to provide a 1/4" nominal clearance between the periphery of the conveyor screw and the inside of the housing. Replacement of screws requires some disassembly.

Types, Sizes and Capacities

Types C, G and J feature a horizontal feeder screw. This provides the controlled feeding that must be adapted for the vertical elevation of material.

Types E and H are gravity fed and can be used when handling materials that are of a granular nature and where the flow of material is governed or controlled by preceding equipment such as another conveyor, vane feeder, etc.

Under normal conditions, Screw-Lifts will handle the following capacities on most materials. On certain dry, free-flowing materials, the capacity can be significantly increased.

Screw-Lift Diameter Inches	Nominal Rated Capacity Cu. Ft. Per Hour
6"	300
9"	1000
12"	2500

With a full knowledge of your conveying needs, our Engineers will design a Screw-Lift for your particular requirements.

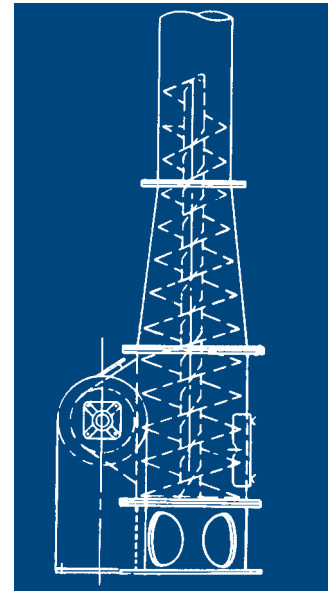

The expanded feeder junction provides for 130% more capacity to relieve choking, back-pressure and material degradation.

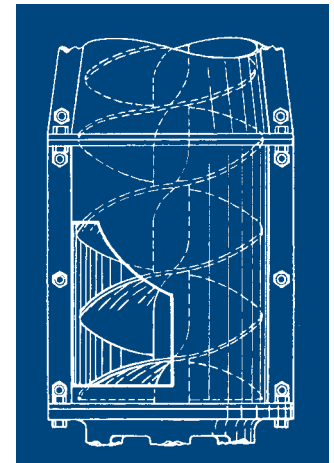

The quarter-segment opening permits exact loading, but no overloading, of the Screw-Lift.

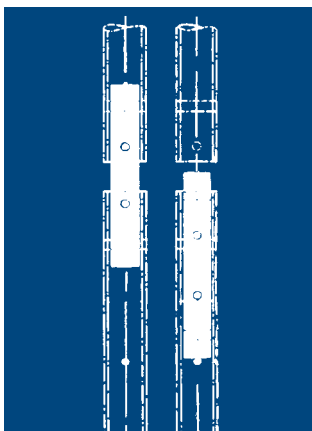

Slip couplings permit quick removal of any conveyor section. Note the stop pin which holds the coupling in readiness.

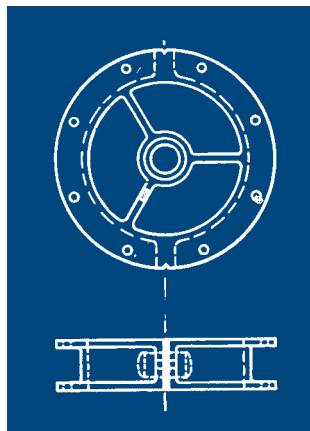

Split stabilizer bearings eliminate whip and vibration and assure quiet operation whether the unit is loaded or empty.

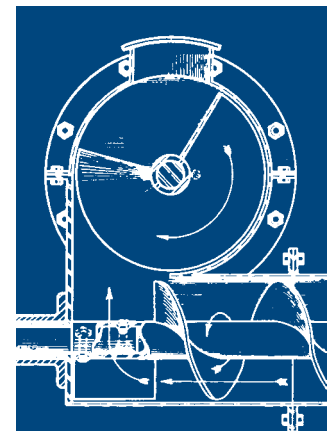

The feeder screw is coordinated with the vertical screw to ensure high material transfer efficiency.



TYPE C

Type C Screw-Lift is equipped with a horizontal feeder screw that is synchronized with the vertical screw for proper feeding at the proper rate. The bottom drive unit is equipped with roller bearings and cut forged steel gears running in a continuous oil bath. Both the horizontal and vertical conveyors are operated with one motor and drive. The length of the horizontal and vertical portions of the Screw-Lift are fabricated to meet individual requirements (minimum lift height 8'8").

DIMENSION DATA

DIAMETER SIZE	6-in. C-300	9-in. C-1000	12-in. C-2500
A	24	27	33 ^{13/16}
B	16 ^{1/8}	19 ^{7/16}	25 ^{5/8}
C	5	5	6 ^{3/4}
D	3	3 ^{1/2}	6 ^{1/2}
E	6	8	10 ^{1/2}
F	8 ^{1/4}	11 ^{7/8}	15 ^{3/4}
G	11 ^{1/2}	11 ^{1/2}	15 ^{3/4}
H	4 ^{1/16}	4 ^{11/16}	6 ^{1/8}
J	1 ^{1/8}	1 ^{3/8}	1 ^{5/8}
N	5	7 ^{1/8}	8 ^{7/8}
O	7x7	10x10	13x13
P	10	13 ^{1/2}	20
Q	2 ^{1/16}	2	1 ^{1/2}
R	3	4 ^{1/4}	5
S	^{13/16}	^{5/8}	^{7/8}
T	11 ^{7/8}	15 ^{3/8}	22 ^{3/8}
U	1 ^{1/16}	1	1 ^{1/4}
V	1 ^{7/8}	1 ^{7/8}	2 ^{3/8}
X	^{13/16}	^{5/8}	^{7/8}
Y	2 ^{13/16}	4	5 ^{1/8}
AA	3	4	5 ^{1/4}
BB	13 ^{1/4}	17 ^{1/2}	24 ^{1/4}
CC	12 ^{1/16}	12 ^{1/16}	13 ^{7/8}
DD	1 ^{1/2}	1 ^{1/2}	2 ^{7/16}
EE	^{13/16}	^{13/16}	^{7/8}
FF	^{7/16}	^{9/16}	^{11/16}
HH	^{7/16}	^{7/16}	^{7/16}
JJ	10 ^{1/4}	13 ^{1/4}	17 ^{1/4}
LL	5 ^{7/8}	7 ^{7/8}	11 ^{7/8}
MM	7	10	12 ^{3/4}
NN	5 ^{5/8}	7 ^{7/8}	9 ^{5/8}
Projection Capacity Cu./Ft./Hr.	300	1000	2500
Input R.P.M.	300	250	250

Note: All dimensions may vary ±1/16".

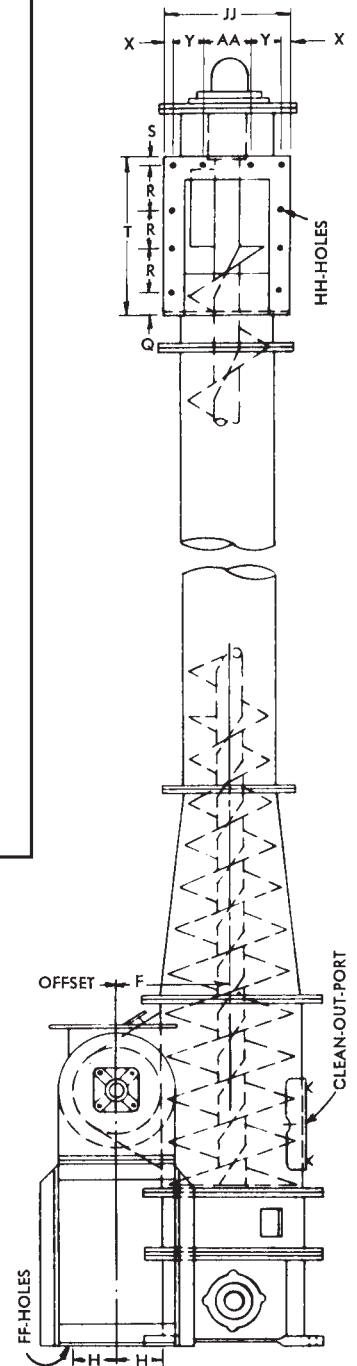
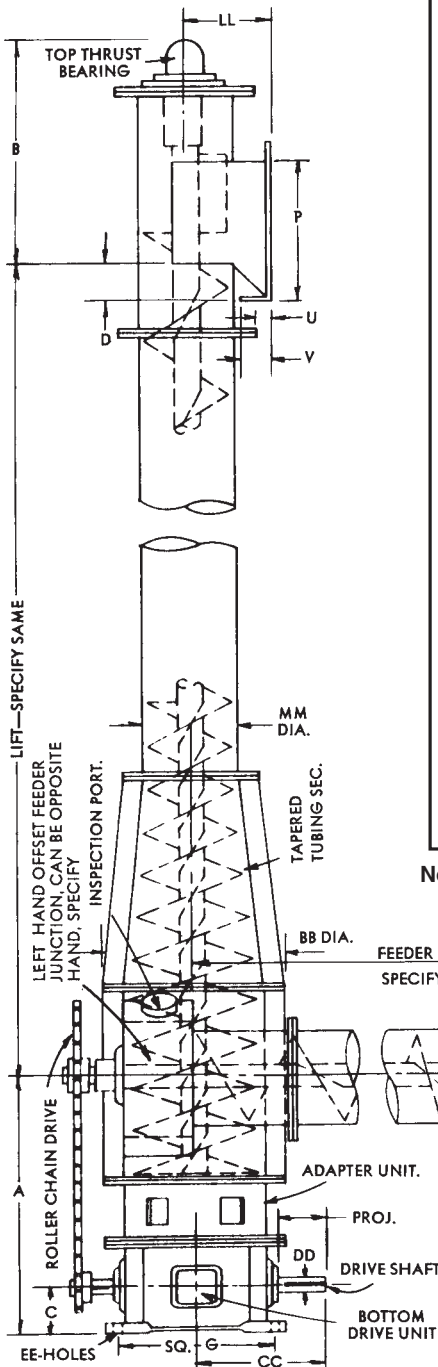



TYPE E

The Type E Screw-Lift is gravity fed and is designed for use where the rate of flow is regulated by preceding equipment. The material should be of sufficient weight and flowability so that it will not tend to bridge in the hopper or blow back. The inlet spout is designed to fit the bottom of a feeding hopper or the discharge spout of a horizontal screw conveyor. This unit is driven from the bottom and the power is transmitted through the bottom drive unit which is equipped with roller bearings and cut forged steel gears running in a continuous oil bath. The height of the Screw-Lift is supplied to suit individual requirements (minimum lift height 8'8").

DIMENSION DATA

DIAMETER	6-in.	9-in.	12-in.
SIZE	E-300	E-1000	E-2500
A	24	27	33 ¹³ / ₁₆
B	16 ⁷ / ₈	19 ⁷ / ₁₆	25 ⁵ / ₈
C	5	5	6 ³ / ₄
D	3	3 ¹ / ₂	6 ¹ / ₂
F	10 ⁷ / ₈	15 ⁵ / ₈	21 ¹ / ₂
G	11 ¹ / ₂	11 ¹ / ₂	15 ³ / ₄
J	1 ¹ / ₄	1 ⁷ / ₈	2 ⁵ / ₈
N	32	38	49 ⁷ / ₁₆
O	7x7	10x10	13x13
P	10	13 ¹ / ₂	20
Q	2 ¹ / ₁₆	2	1 ¹ / ₂
R	3	4 ¹ / ₄	5
S	1 ³ / ₁₆	5 ⁵ / ₈	7 ⁷ / ₈
T	11 ⁷ / ₈	15 ⁵ / ₈	22 ³ / ₈
U	1 ¹ / ₁₆	1	1 ¹ / ₄
V	1 ⁷ / ₈	1 ⁷ / ₈	2 ³ / ₈
X	1 ³ / ₁₆	5 ⁵ / ₈	7 ⁷ / ₈
Y	2 ¹³ / ₁₆	4	5 ¹ / ₈
AA	3	4	5 ¹ / ₄
BB	13 ³ / ₄	17 ¹ / ₂	24 ¹ / ₄
CC	12 ¹ / ₁₆	12 ¹ / ₁₆	13 ⁷ / ₈
DD	1 ¹ / ₂	1 ¹ / ₂	2 ¹ / ₁₆
EE	1 ³ / ₁₆	1 ³ / ₁₆	7 ⁷ / ₈
GG	5 ⁷ / ₈	7 ⁷ / ₈	11 ⁷ / ₈
HH	7 ⁷ / ₁₆	7 ⁷ / ₁₆	7 ⁷ / ₁₆
JJ	10 ¹ / ₄	13 ³ / ₄	17 ¹ / ₄
KK	7	10	13
LL	7	10	12 ³ / ₄
Projection	5	5	5
Capacity			
Cu./Ft./Hr.	300	1000	2500
Input R.P.M.	300	250	250

Note: All dimensions may vary $\pm 1/16$ ".

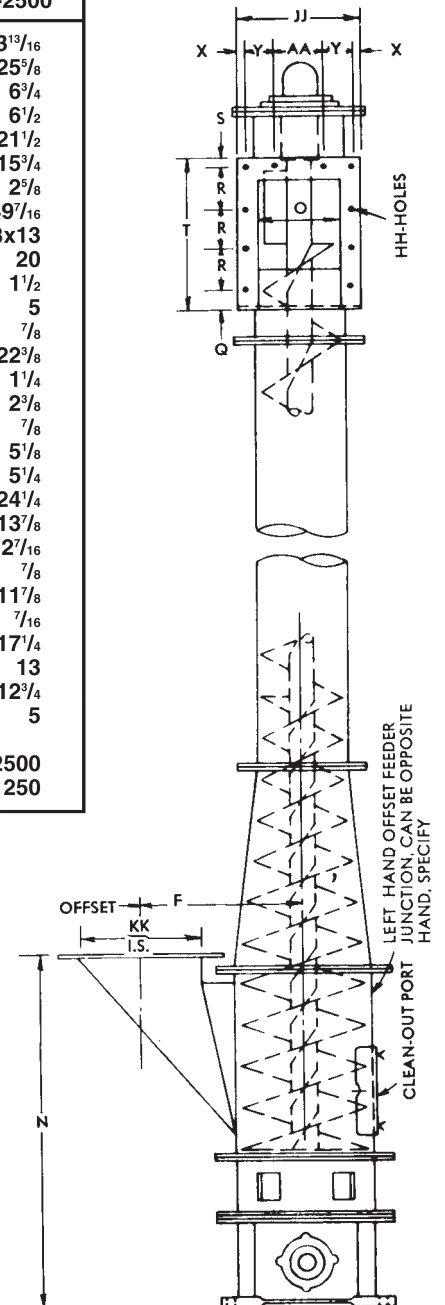
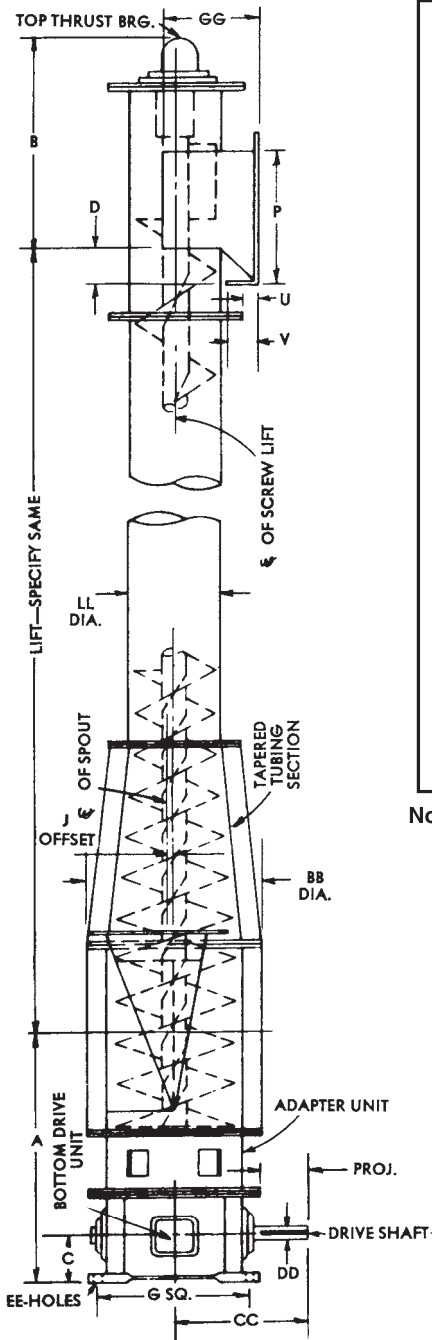



TYPE G

The Type G Screw-Lift, vertical screw conveyor, comes standard with a flange mounted reducer and a c-faced motor. The horizontal screw conveyor feeder is driven separately at the bottom at a speed that regulates flow of material at the desired capacity. The length of both the vertical and horizontal members are furnished to suit individual requirements (minimum lift height 8'8").

DIMENSION DATA

DIAMETER → SIZE	6-in.	9-in.	12-in.
	G-300	G-1000	G-2500
A	17 ³ / ₄	20 ³ / ₄	24 ¹ / ₄
B	21 ¹ / ₈	24 ¹ / ₄	31 ⁹ / ₁₆
D	3	3 ¹ / ₂	6 ¹ / ₂
E	6	8	10 ¹ / ₂
F	8 ¹ / ₄	11 ⁷ / ₈	15 ³ / ₄
G	15	19 ¹ / ₂	26 ³ / ₈
H	4 ¹ / ₁₆	4 ¹¹ / ₁₆	6 ¹ / ₈
J	1	1 ¹ / ₂	1 ⁵ / ₈
N	5	7 ¹ / ₈	8 ⁷ / ₈
O	7x7	10x10	13x13
P	10	13 ¹ / ₂	20
Q	2 ¹ / ₁₆	2	1 ¹ / ₂
R	3	4 ¹ / ₄	5
S	1 ³ / ₁₆	5 ⁵ / ₈	7 ⁷ / ₈
T	11 ⁷ / ₈	15 ³ / ₈	22 ³ / ₈
U	1 ¹ / ₁₆	1	1 ¹ / ₄
V	1 ⁷ / ₈	1 ⁷ / ₈	2 ³ / ₈
X	1 ³ / ₁₆	5 ⁵ / ₈	7 ⁷ / ₈
Y	2 ¹³ / ₁₆	4	5 ¹ / ₈
AA	3	4	5 ¹ / ₄
BB	13 ¹ / ₄	17 ¹ / ₂	24 ¹ / ₄
EE	1 ³ / ₁₆	1 ³ / ₁₆	1 ³ / ₁₆
FF	7 ⁷ / ₁₆	9 ⁹ / ₁₆	11 ¹¹ / ₁₆
HH	7 ⁷ / ₁₆	7 ⁷ / ₁₆	7 ⁷ / ₁₆
JJ	10 ¹ / ₄	13 ¹ / ₄	17 ¹ / ₄
MM	7	10	12 ³ / ₄
Capacity Cu./Ft./Hr.	300	1000	2500
Input R.P.M.	300	250	250

Note: All dimensions may vary ±1/16".

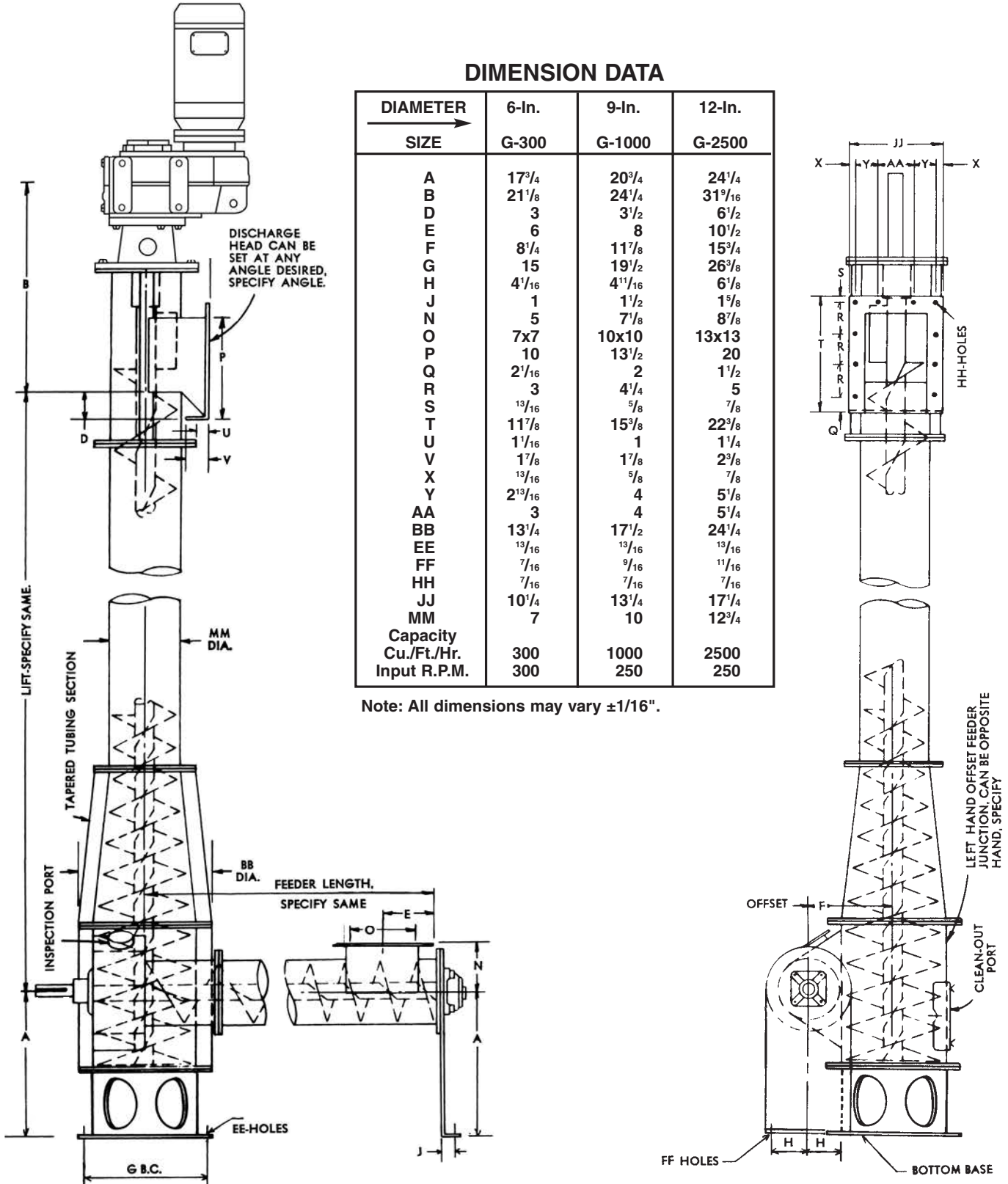



TYPE H

The Type H Screw-Lift is gravity fed for use with certain classes of materials where the rate of flow is uniformly controlled by preceding equipment. The material should be of sufficient weight and flowability so that it will not tend to bridge in the hopper or blow back. The inlet spout is designed to fit the bottom of a feeding hopper or the discharge spout of a horizontal screw conveyor. Our standard package includes a flange mounted reducer and a c-faced motor. The height of the Screw-Lift is fabricated to suit individual requirements (minimum lift height 8'8").

DIMENSION DATA

DIAMETER → SIZE	6-in. H-300	9-in. H-1000	12-in. H-2500
A	17 ³ / ₄	20 ³ / ₄	24 ¹ / ₄
B	21 ¹ / ₈	24 ¹ / ₄	31 ⁹ / ₁₆
D	3	3 ¹ / ₂	6 ¹ / ₂
F	10 ⁷ / ₈	15 ⁵ / ₈	21 ¹ / ₂
J	10 ¹ / ₄	13 ³ / ₄	17 ¹ / ₄
N	25 ³ / ₄	31 ³ / ₄	39 ⁷ / ₈
P	10	13 ¹ / ₂	20
Q	2 ¹ / ₁₆	2	1 ¹ / ₂
R	3	4 ¹ / ₄	5
S	¹³ / ₁₆	⁵ / ₈	⁷ / ₈
T	11 ⁷ / ₈	15 ³ / ₈	22 ³ / ₈
U	1 ¹ / ₁₆	1	1 ¹ / ₄
V	1 ⁷ / ₈	1 ⁷ / ₈	2 ³ / ₈
X	¹³ / ₁₆	⁵ / ₈	⁷ / ₈
Y	2 ¹³ / ₁₆	4	5 ⁵ / ₈
AA	3	4	5 ¹ / ₄
BB	13 ³ / ₄	17 ¹ / ₂	24 ¹ / ₄
EE	¹³ / ₁₆	¹³ / ₁₆	¹³ / ₁₆
FF	7	10	12 ³ / ₄
GG	15	19 ¹ / ₂	26 ³ / ₈
HH	⁷ / ₁₆	⁷ / ₁₆	⁷ / ₁₆
JJ	1 ¹ / ₄	1 ⁷ / ₈	2 ⁵ / ₈
KK	7	10	13
Capacity Cu./Ft./Hr.	300	1000	2500
Input R.P.M.	300	250	250

Note: All dimensions may vary ±1/16".

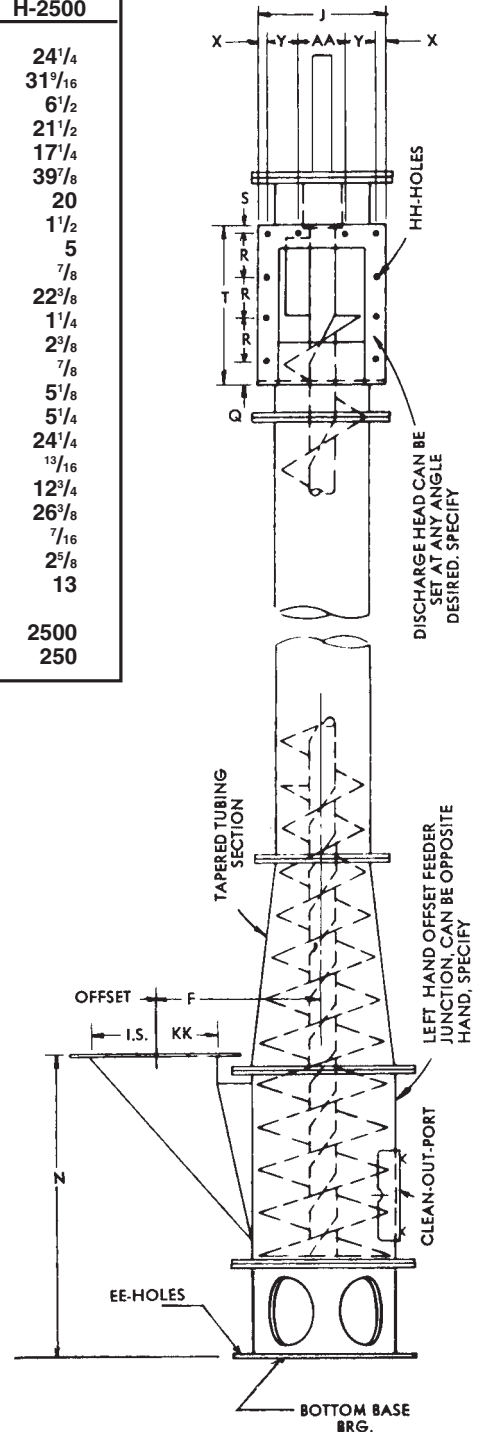
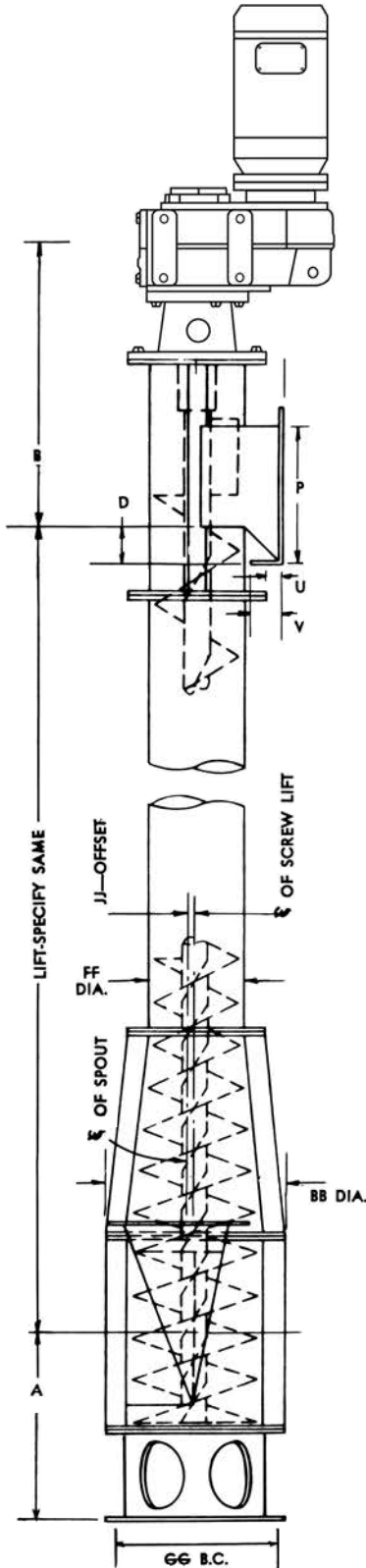



TYPE J

The horizontal screw conveyor feeder is designed to regulate the input and allows the Type J Screw-Lift to handle virtually all types of free-flowing bulk materials. The drive from the top of the unit powers the vertical screw as well as the horizontal feeder screw through the bottom power take-off unit. The length of both the vertical and horizontal members are furnished to suit individual requirements.

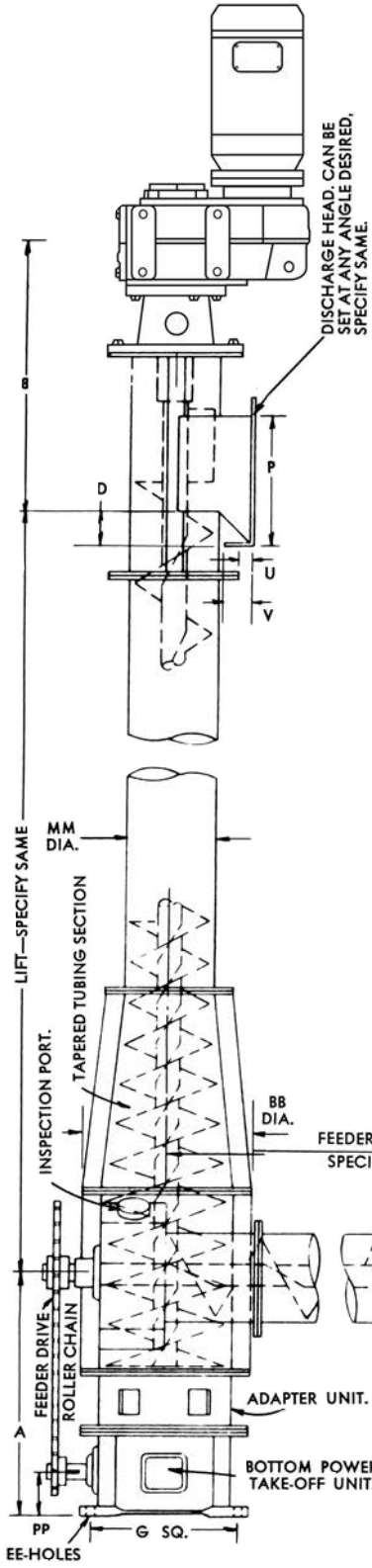

DIMENSION DATA

DIAMETER SIZE →	6-in. J-300	9-in. J-1000	12-in. J-2500
A	24	27	33 ³ / ₁₆
B	21 ¹ / ₈	24 ¹ / ₄	31 ³ / ₁₆
D	3	3 ¹ / ₂	6 ¹ / ₂
E	6	8	10 ¹ / ₂
F	8 ³ / ₄	11 ⁷ / ₈	15 ³ / ₄
G	11 ¹ / ₂	11 ¹ / ₂	15 ³ / ₄
H	4 ¹ / ₁₆	4 ¹¹ / ₁₆	6 ⁷ / ₈
J	1 ¹ / ₈	1 ³ / ₈	1 ⁵ / ₈
N	5	7 ¹ / ₈	8 ⁷ / ₈
O	7x7	10x10	13x13
P	10	13 ¹ / ₂	20
Q	2 ¹ / ₁₆	2	1 ¹ / ₂
R	3	4 ¹ / ₄	5
S	¹³ / ₁₆	⁵ / ₈	⁷ / ₈
T	11 ⁷ / ₈	15 ³ / ₈	22 ³ / ₈
U	1 ¹ / ₁₆	1	1 ¹ / ₄
V	1 ⁷ / ₈	1 ⁷ / ₈	2 ³ / ₈
X	¹³ / ₁₆	⁵ / ₈	⁷ / ₈
Y	2 ¹³ / ₁₆	4	5 ⁵ / ₈
AA	3	4	5 ¹ / ₄
BB	13 ³ / ₄	17 ¹ / ₂	24 ³ / ₄
EE	¹³ / ₁₆	¹³ / ₁₆	⁷ / ₈
FF	⁷ / ₁₆	⁹ / ₁₆	¹¹ / ₁₆
HH	⁷ / ₁₆	⁷ / ₁₆	⁷ / ₁₆
JJ	10 ¹ / ₄	13 ³ / ₄	17 ¹ / ₄
MM	7	10	12 ³ / ₄
NN	5 ⁵ / ₈	7 ⁷ / ₈	9 ⁵ / ₈
PP	5	5	6 ³ / ₄
Capacity Cu./Ft./Hr.	300	1000	2500
Input R.P.M.	300	250	250

Note: All dimensions may vary ±1/16".

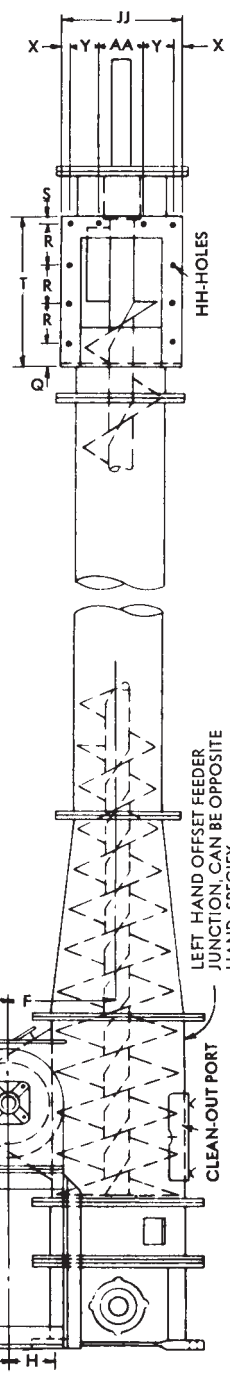



QUICK OPENING FEATURE

All types and sizes of the Screw-Lift shown on previous pages can be manufactured with the Quick-Opening feature. These are generally used where quick and easy access to the interior of the unit is required for inspection and cleaning.

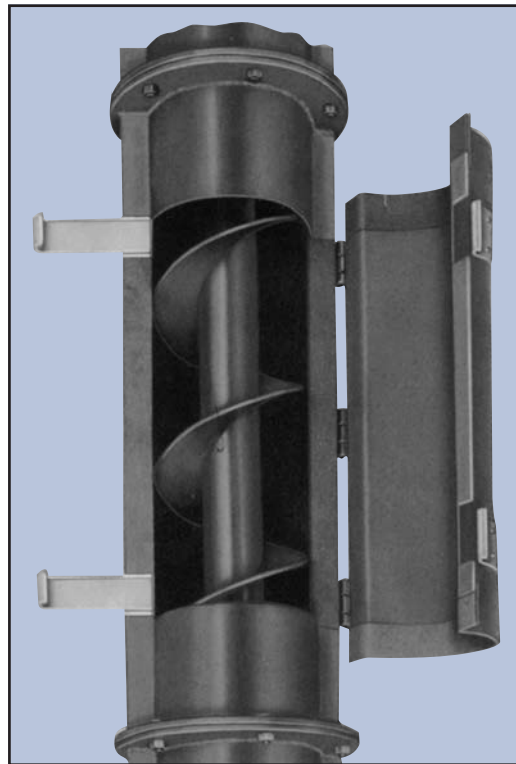
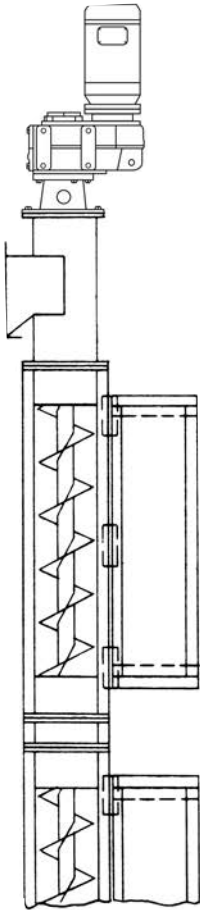

Do not operate with door open.

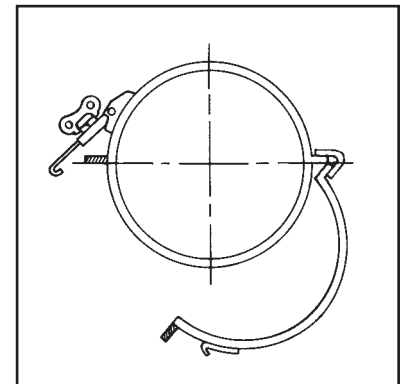
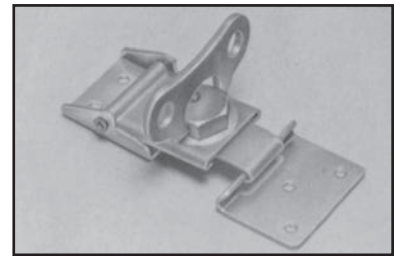

Hinges and heavy duty quick release clamps result in fast and easy opening. Food grade gaskets are located at all horizontal and vertical flanges as standard.

Cross-section view shows hinged section open. Quick-Release Clamps hold flanges tight when unit is closed.

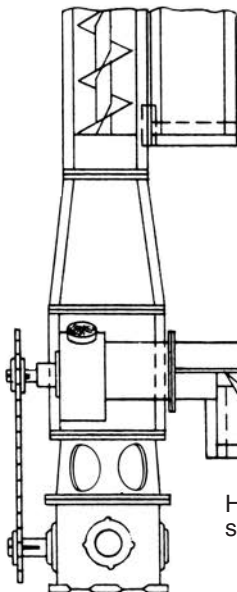

Hinged sections of the vertical and horizontal tubing shown in open position.

EXPERIENCE IN MOTION

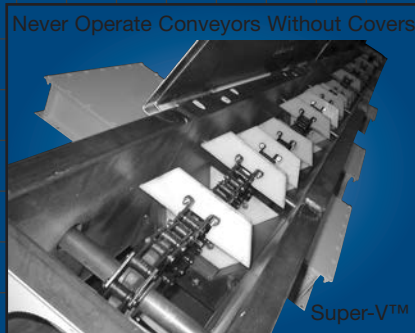
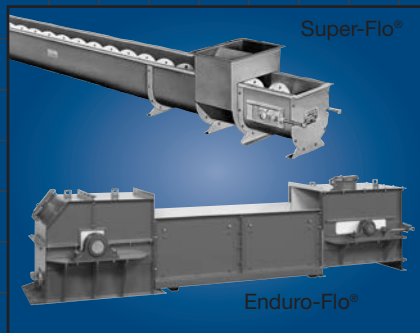
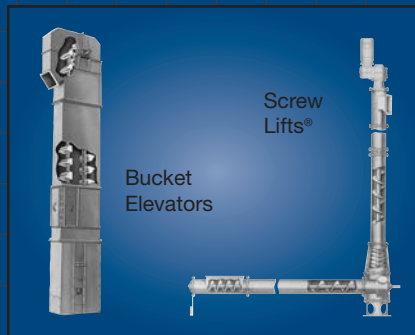
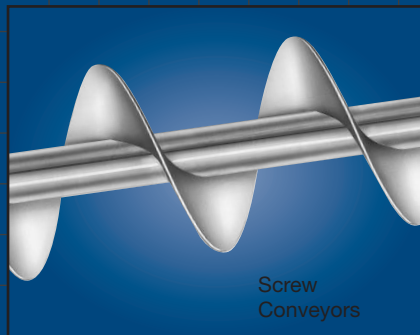

For Over 75 Years We Have Been A Dependable Source For
Performance Proven Industrial Bulk Material Handling
Equipment.
Put Our Experience to Work for You.



THE EXPERIENCE
TO HANDLE IT RIGHT!®

Screw Conveyor Corporation®

700 HOFFMAN STREET, HAMMOND, INDIANA 46327-1894 PHONE 219-931-1450 FAX: 800-805-6527 WEB ADDRESS: www.screwconveyor.com
Winona, MS 662-283-3142 Visalia, CA 559-651-2131 Chanute, KS 620-431-0440 Guadalajara, Jal. Mexico 333-645-7110
FAX: 800-213-3084 FAX: 800-651-2135 FAX: 800-213-3086 FAX: 333-663-2369